

WHEEL TYPE 1 (SIDE VIEW)

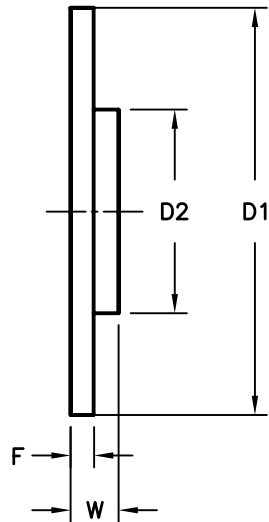

WHEEL TYPE 2 (SIDE VIEW)

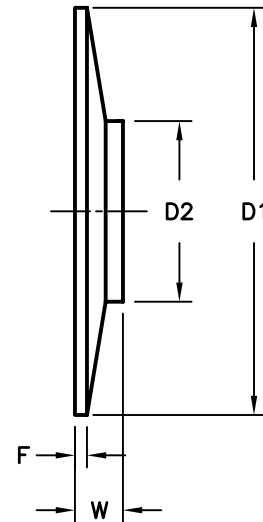

WHEEL TYPE 3 (SIDE VIEW)

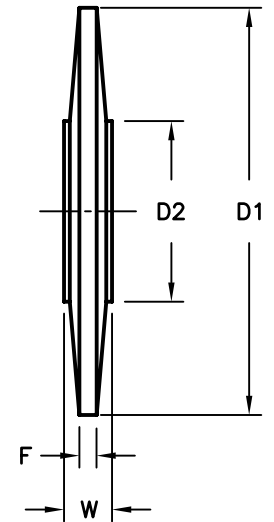

WHEEL TYPE 4 (SIDE VIEW)

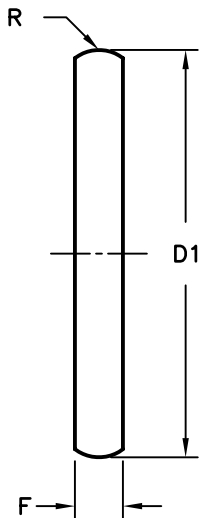

WHEEL TYPE 1R (SIDE VIEW)

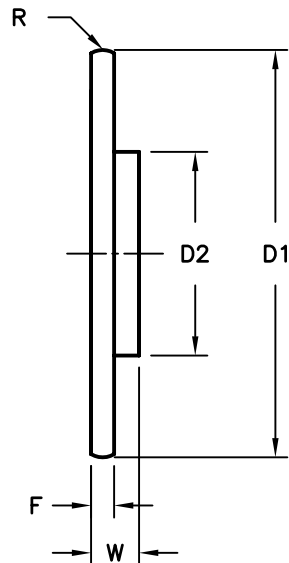

WHEEL TYPE 2R (SIDE VIEW)

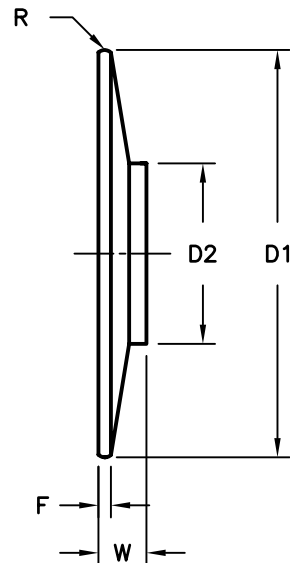

WHEEL TYPE 3R (SIDE VIEW)

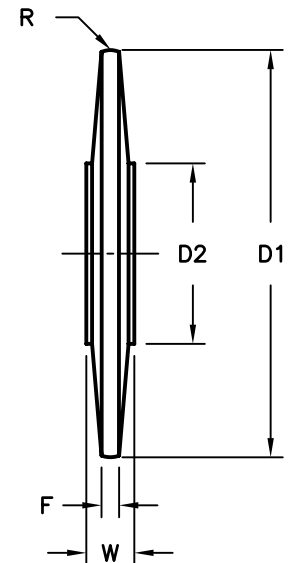

WHEEL TYPE 4R (SIDE VIEW)

**STEP ONE: CHOOSE WHEEL TYPE**

WT=WHEEL TYPE, R=RADIUS, D1=WHEEL DIA.,  
D2=HUB DIA., F=WELD FACE, W=WHEEL THICKNESS.

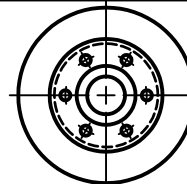

UNLESS OTHER-  
WISE SPECIFIED,  
TOLERANCES:  
FRACTIONS= $\pm 1/32$   
DEC .XX= $\pm .015$   
DEC .XXX= $\pm .005$   
ANGLES= $\pm 1/2^\circ$



SCALE  
NONE

DWG. SIZE A DWG. NO. 6200 (1 OF 2) REV.

STEP 2: PILOT TYPE AND DIAMETER

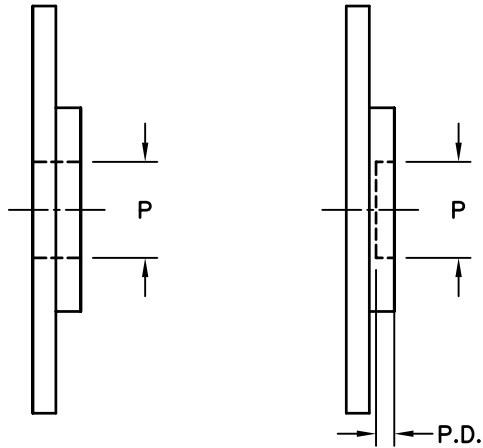

STEP 4: SELECT MATERIAL

- CLASS 1 COPPER, ZIRCONIUM
- CLASS 2 COPPER, CHROMIUM, ZIRCONIUM
- CLASS 3 COPPER, NICKEL, BERYLLIUM
- CLASS 11 TUNGSTEN COPPER (ELKONITE 10W3)
- CLASS 13 TUNGSTEN COPPER (ELKON 100W)

STEP 5: CONFIGURE WHEEL

WT: \_\_\_\_\_

R: \_\_\_\_\_

D1: \_\_\_\_\_

D2: \_\_\_\_\_

F: \_\_\_\_\_

W: \_\_\_\_\_

P: \_\_\_\_\_

PD: \_\_\_\_\_

BC: \_\_\_\_\_

N: \_\_\_\_\_

T: \_\_\_\_\_

MAT'L: \_\_\_\_\_

STEP 3: MOUNTING DEFINITION

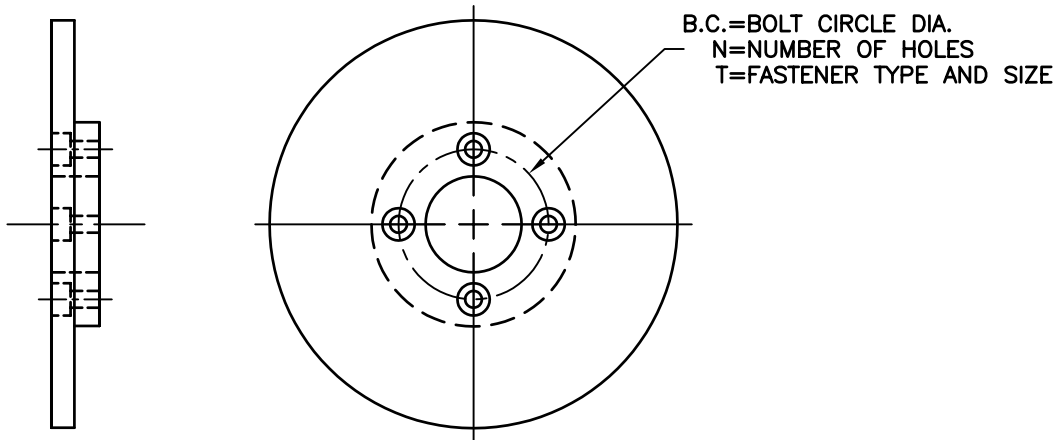

NOTES:

STEP TWO: PILOT TYPE

P=PILOT DIA., PD=PILOT DEPTH.

STEP THREE: MOUNTING TYPE AND BOLT CIRCLE DEFINITION

B.C.=BOLT CIRCLE DIA., N=NUMBER OF HOLES, T=FASTENER TYPE AND SIZE.

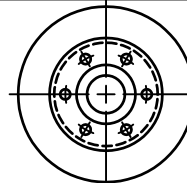

UNLESS OTHER-  
WISE SPECIFIED,  
TOLERANCES:  
FRACTIONS=±1/32  
DEC .XX=±.015  
DEC .XXX=±.005  
ANGLES=±1/2°



SCALE	DWG. SIZE	DWG. NO.	REV.
NONE	A	6200 (2 OF 2)	